

- 0
- 0
- 0
- 0
- 1
- 2
- 3
- 4
- 5
- 6
- 7
- 8

Version No.			

ROLL NUMBER						

- 0 0 0 0 0 0 0 0 1 1
- 1 1 1 1 1
- 2 2 2 2 2 2 2
- 3 3 3 3 3 3 3
- 4 4 4 4 4 4 4
- 5 5 5 5 5 5 5
- 6 6 6 6 6 6 6
- 7 7 7 7 7 7 7
- 8 8 8 8 8 8 8
- 9 9 9 9 9 9 9



Answer Sheet No. _____

Sign. of Candidate _____

Sign. of Invigilator _____

COMPUTER SCIENCE HSSC-I (2nd Set Solution)
SECTION – A (Marks 15)
Time allowed: 20 Minutes

Section – A is compulsory. All parts of this section are to be answered on this page and handed over to the Centre Superintendent. Deleting/overwriting is not allowed. **Do not use lead pencil.**

Q.1 Fill the relevant bubble for each part. Each part carries one mark.

- (1) Which pointing device is popular with ATM machines?
 A. Touch Pad B. Trackball
 C. Touch Screen D. Light Pen
- (2) Which device reads the information of owner from Credit Card?
 A. Bar Code Reader B. Magnetic Card Reader
 C. Optical Scanner D. Handheld Scanner
- (3) What is the full form of WAP?
 A. Wireless Access Place B. Wireless Access Protocol
 C. Wireless Access Plane D. Wireless Access Portion
- (4) Which one of the following Orbits is at the distance of 22,000 miles from the surface of the Earth?
 A. GEO B. MEO
 C. LEO D. HEO
- (5) Which one of the following is an example of One-to-Many relationship?
 A. Class → Teacher
 B. College Campus → Teacher C. College → Principal
 D. Country → Capital
- (6) Which device use spindle to hold the disk(s)?

- A. Compact Disk B. Floppy Disk
C. Hard Disk D. DRAM

- (7) Which device have instructions to load operating system from hard disk to RAM?
A. RAM B. Cache
C. ROM D. Register

Page 1 of 2

- (8) Which theoretical foundation of a data base determines that how data is stored, organized, and manipulated?
A. Database Model B. Database Structure
C. Database Design D. Database Architecture

- (9) Which component generates a signal to execute an instruction?
A. ALU B. Decoder
C. Cache D. Timing & Control Logic

- (10) Which one of the following is uni-directional bus?
A. Data B. Network C. Address D. System

- (11) Which one of the following is Data Transfer Instruction?
A. STORE B. LOOP
C. SHIFT D. JMP

- (12) For which purpose Class C is used?
A. Small size network B. Multicasting
C. Large size network D. Broadcasting

- (13) Which one of the following Network devices is used to forward data packets across similar or different networks?
A. Server B. Router
C. Modem D. Gateway

- (14) Which datatype is most suitable for storing address of Employee?
A. Short Text B. Long Text
C. Yes/No D. Date/Time

- (15) Which one of the following port is **Not** replaced by USB port?
A. Serial B. Firewire
C. Parallel D. PS/2



Page 2 of 2

Federal Board HSSC-I Examination
Computer Science Model Question Paper
(Curriculum 2009)

Time allowed: 2.40 hours

Total Marks: 60

Note: Answer any twelve parts from Section 'B' and attempt any three questions from Section 'C' on the separately provided answer book. Write your answers neatly and legibly.

SECTION – B (Marks 36)

Q.2 Attempt any **TWELVE** parts from the following. All parts carry equal marks. (12×3=36)

i. Why **LCD** is better than **CRT** monitors? Justify your answer with three reasons.

Ans. LCD (Liquid crystal display) is much better and more commonly used now-adays because of the following reasons:

- It produces sharper and **better image** as compared to CRT monitors.
- It consumes **less power**.
- It emits **less radiation** as compared to CRT monitors.
- It **weighs less**.

ii. Write down one example of each Productivity Software, Open-Source Software and Device Driver.

Ans. **Productivity Software:** Word-processing, Spreadsheet
Open-Source Software: LINUX, Firefox
Device Driver: Printer driver, Mouse driver

iii. Which pointing device is available in laptop? How it differs from a mouse? Give two reasons.

Ans. **Touchpad** is a pointing device used as an alternate of mouse in laptop.

It differs from the mouse in the following ways:

- 1) It is a **flat pressure sensitive surface** whereas a mouse is not flat and pressure sensitive.
- 2) Pointer movement is controlled by **sliding fingertip** on it. In mouse, movement is controlled by dragging mouse on surface.

iv. What are the two basic components of CPU? Illustrate with diagram.

Ans. The two basic components of the CPU are **ALU (Arithmetic and Logic Unit)** and **CU (Control Unit)**.

ALU: It is the part of CPU where actual programming takes place.

CU: It controls and coordinate the activities of the entire computer system.

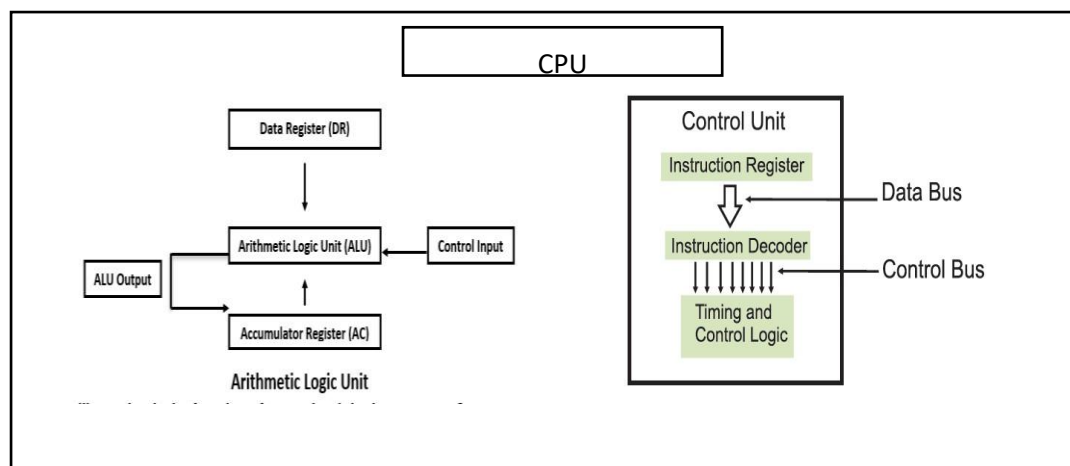

v. What is Memory Word? How size of Memory word affects the speed of computer?

Ans. The **smallest size of data** processed by the CPU is called memory word. It is number of bits transferred during read or write operation. So, larger the size of memory word, means the more bits transferred or processed at one time and it will increase the speed of computer.

vi. Write down the purpose of **EPROM** and **EEPROM**.

Ans. **EPROM:** It stands for Electrically EPROM. No need to remove it from the computer for reprogramming. It can be reprogrammed many times using electric current. It needs special software for programming.

EEPROM: It stands for Erasable PROM. It must be removed from the computer for reprogramming. It can be reprogrammed many times using ultraviolet rays. It needs special equipment for reprogramming.

vii. Which port is **plug and play**? Why is it called plug and play? Give two reasons.

Ans. **USB port** is a plug n' play port, and the mostly used port in a computer. It is called a plug and play port because it automatically detects what type of device is attached to a computer. After detecting it automatically installs the driver for it. Hence, as the name suggests you can plug in a device in this port and start using it without having to install its driver.

viii. Write down the functions of **Memory Address Register** and **Program Counter**? How are they linked?

Ans. **MEMORY ADDRESS REGISTER:**

- It holds the address of a **memory location being accessed** by the CPU during read/write operation.

PROGRAM COUNTER:

- It holds the address of the **next instruction** to be fetched from the memory.
- After fetching an instruction, the value of program counter is **incremented by one point**.

LINK BETWEEN MAR & PC:

- The content of program counter is loaded into the memory address register.

ix. Complete the following grid according to the criteria given.

Criteria	OSI	TCP/IP
Developed by		
No of Layers		
Model Type		

Ans.

Criteria	OSI	TCP/IP
Developed by	ISO (International Standard Organization)	US Department of Defense (DoD)
No of Layers	Seven	Four
Model Type	Theoretical/reference Model	Implementation of OSI

x. Write down any three differences between **CISC** and **RISC**. Ans. (any three valid points)

CISC ARCHITECTURE	RISC ARCHITECTURE
It utilizes more than one cycle to execute the instruction.	utilizes only one cycle to execute an instruction.
It reduces the length of the code. It increases the	length of the code.
It requires little RAM to store instruction. It	requires more RAM to store instruction.
Its execution speed is slow. Its execution speed	is fast.
It has complex instruction architecture. It has	simple instruction architecture.
It is used in computers. It is used in laptops,	mobiles phones, tablets etc.

xi. Write down three applications of **Virtual Private Network**?

Ans. Applications are:

- It is used in offices or universities for video conferencing.
- It is used in different departments for data (in any form) sharing.
- It is used by employees of an organization for secure and remote access to private network.

xii. What are three components required for **Mobile Communication Network**.

Ans. (any three valid components)

- 1) Mobile Phone: It is a device that allows us to make or receive calls over a cellular network.
- 2) Base Station: It is responsible for handling traffic and signaling between mobile phones.
- 3) Switching Node: It carries out switching and mobility functions.
- 4) Landline Telephone Network: It is wired PSTN that provide communication between mobile phone and telephone.

xiii. What is **Wireless Network**? Give one advantage and one disadvantage.

Ans.

It is a network in which nodes are connected wirelessly using any wireless technology like Wi-Fi, Bluetooth etc. (any one valid advantage/disadvantage)

Advantage: Easily add users without changing the physical connections

Disadvantage: Its speed is slower than wired network.

xiv. In an organization, an employee assigned a single login and he work under only one department. Draw ER diagram of given scenario. Ans.

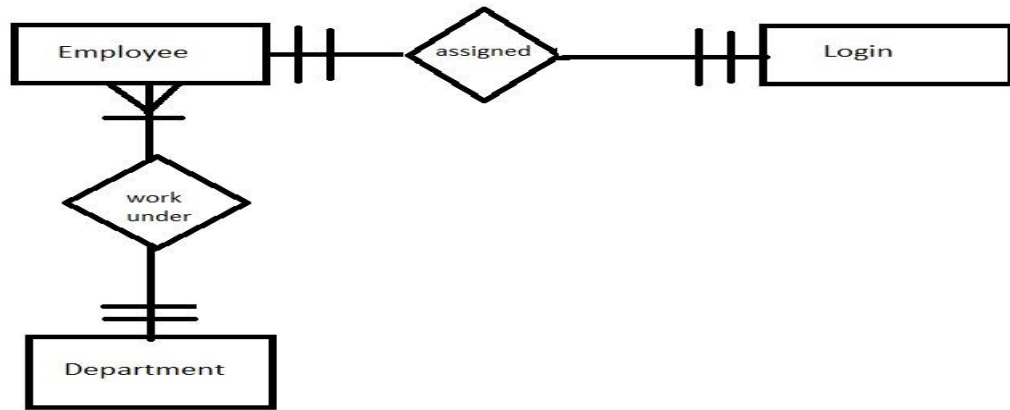

xv. Determine the type of database language by the commands given of each type:

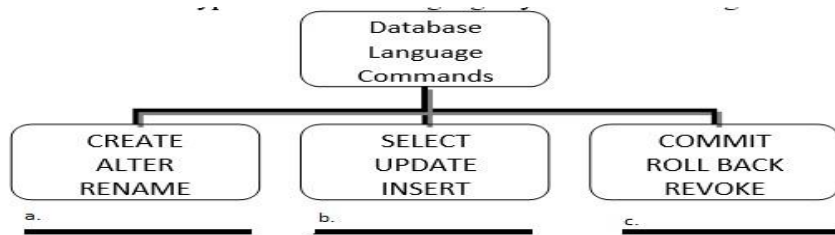

Ans.

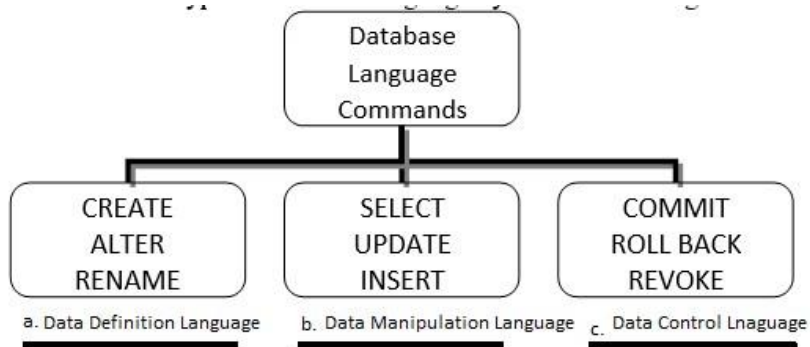

xvi. Select the suitable datatypes for respective fields.

Book Id	Book Title	Publish Date	Available	Price	Remarks
3625	Network Fundamentals	26-Feb-2018	Yes	800\$	Book covers the topics....
3626	Oracle SQL	16-June-2005	No	900\$	Book covers the topics....
3627	Introduction to Computer	12-Dec-2011	Yes	745\$	Book covers the topics....

Ans. Book_Id:
Autonumber/Number
Book Title: Short Text
Publish Date: Date/Time
Available: Yes/NO
Price: Currency
Remarks: Long Text

SECTION – C (Marks 24)

Note: Attempt any **TWO** questions. All questions carry equal marks.

(2 * 12 = 24)

Q.3 a. Describe instructions with its parts. Briefly explain three types of instructions with example. (8)

Ans. **INSTRUCTION**

It is also called **instruction code**. It is a group of bits that instruct the computer to perform a specific task. They are stored in a continuous location and are executed in sequence. An instruction has two parts:

- **Operation Code**, represents the action that processor will execute
- **Operand Code**, Defines the parameters of the action. It depends on the operation. It can be data or a memory address.

Operation Code	Operand Code
-----------------------	---------------------

Types:

1) DATA TRANSFER INSTRUCTION:

It is used for transferring data from one location in the computer to another location without changing the contents. It transfers data between; register & memory, register & input/output devices, register & register. **Example:** MOVE (MOV), LOAD (LD), STORE (STO)

2) DATA PROCESSING INSTRUCTION:

It is used for performing arithmetic and logic operations. It is performed on the values of Data Register and Accumulator Register. It has 3 types: **Arithmetic Instruction, Logical Instruction, Shift Instruction.**

3) PROGRAM CONTROL:

It is used to control the sequence in which statements are executed. For example:
JUMP, LOOP

b. Read the given description carefully and complete the following grid: (4)

1	2	3
Description	Name of Storage Device	Category of Storage: Primary/Secondary
Volatile memory that is used as cache memory and does not need to be recharged		
Volatile memory that uses laser beam to read/write data and have smaller and very densely packed bumps due to which it has largest storage capacity		

Non-volatile memory that uses electric current to rewrite data and work like flash memory		
Non-volatile memory in which data is accessed sequentially and mostly used for backing purpose		

Ans.

1	2	3
Description	Name of Storage Device	Category of Storage: Primary/Secondary
Volatile memory that is used as cache memory and does not need to be recharged	SRAM	Primary
Volatile memory that uses laser beam to read/write data and have smaller and very densely packed bumps due to which it has largest storage capacity	Blu Ray Disk	Secondary
Non-volatile memory that uses electric current to rewrite data and work like flash memory	EEPROM	Primary
Non-volatile memory in which data is accessed sequentially and mostly used for backing purpose	Magnetic Tape	Secondary

Q.4 Describe the following classification of computers with their applications in daily life:

- i. Supercomputer ii. Mainframe Computer (2+2+2+2) iii. Microcomputer iv. Mobile Computing

Ans. **i. Supercomputer**

It is used to process large amount of data. It is used to process complex calculation. It is used to design and control the complicate machine i.e., rockets. It is big in size. It is very costly. It has very large memory. It has very high processing speed. **Example:** Cray-1

ii. Mainframe Computer

It is used as server computer. It can also handle large amount of data. It can handle thousands of users at the same time. It is less costly and smaller than supercomputer. It can process trillion of instructions per Second (**TIPS**). **Example:** IBM SYSTEM 360

iii. Mobile Computing

It is a technology that uses handheld portable devices for transmission of data (text, audio, and video). These devices are wirelessly connected to a network. They run on batteries and have limited functionality. **Example:** Mobile phone (best example), PDAs, and tablets.

Q.5 Discuss the **Ring** and **Mesh** topologies, with respect to advantages and disadvantages.

Illustrate with the help of diagram.

(4+4)

Ans.

Ring Topology:

□ In this topology, all nodes are attached in such a way that they make a closed loop. The last computer is attached to the first computer to make a ring. Each node receives data from previous computer and send to next computer. The data passed through ring until it reaches to destination.

Advantages:

- It is simple and easy to install.
- It is very cheap.
- It is a collision free topology.
- It is suitable for small network.

Disadvantages:

- If ring breaks, the entire network goes down.
- It is not suitable for large network as increase the number of nodes and it will slow down the network.
- Difficult to locate a problem if networks go down.

Mesh Topology:

□ In this topology, all nodes relate to each other through direct and dedicated link. Each node sends and receives data through dedicated link.

Advantages:

- Easy to locate a problem if network goes down
- Provide high security and privacy.
- It is suitable for high traffic.
- It is most reliable topology.

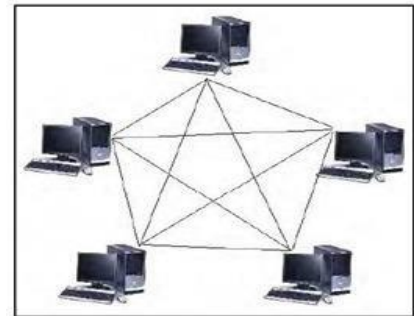

Disadvantages:

- It is the most expensive topology.
- It is difficult to maintain.
- It is not suitable for large network.

Q.6 a. What is Primary Key, Foreign Key, Alternate and Candidate Key? (4)

Ans.

Primary keys:

- An attribute or set of attributes that is used to identify a record in a relation is known as primary key. It should be unique and not null.
- **Example:** A student table contains different attributes such as Roll No. Name, DOB, Address and phone. The attribute Roll No. uniquely identifies each student in the relation so it can be used as primary key.

Candidate Key:

- An attribute or set of attributes that can be used as primary key are called candidate keys.
- **Example:** A student table contains different attributes such as Reg no, Roll No. Name,

DOB, Address and phone. The attribute Reg no. and roll no. can be used to identify each student in the relation. Both attributes are known as candidate keys.

Alternate Key:

- The candidate keys that are not selected as primary key are known as alternate keys.
- **Example:** A student table contains different attributes such as Reg no, Roll No. Name, DOB, Address and phone. The attribute Reg no. and roll no. can be used to identify each student in the relation. If Roll No. is selected as primary key, then Reg no. becomes an alternate key.

Foreign Key:

- A foreign key is an attribute or set of attributes whose values match with a primary key in another relation.
- **Example:** The Roll no. attribute in parent relation is used as primary key. Same Roll No. Attribute in Child relation is used as foreign key.

b. Also identifies them in the following ER-diagram. Mention the cardinality and modality of given entities in the diagram. (2+2)

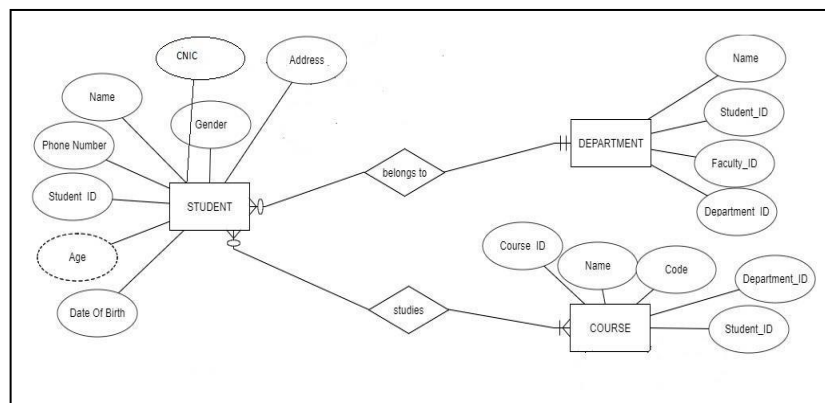

Ans. **Primary Key:**

- Student → Student_Id
- Department → Department_Id
- Course → Course_Id

Candidate Key:

Student → Student_Id, CNIC

Foreign Key:

- Department → Student_Id, Faculty_Id
- Course → Student_Id, Department_Id

Alternate Key:

Student → CNIC

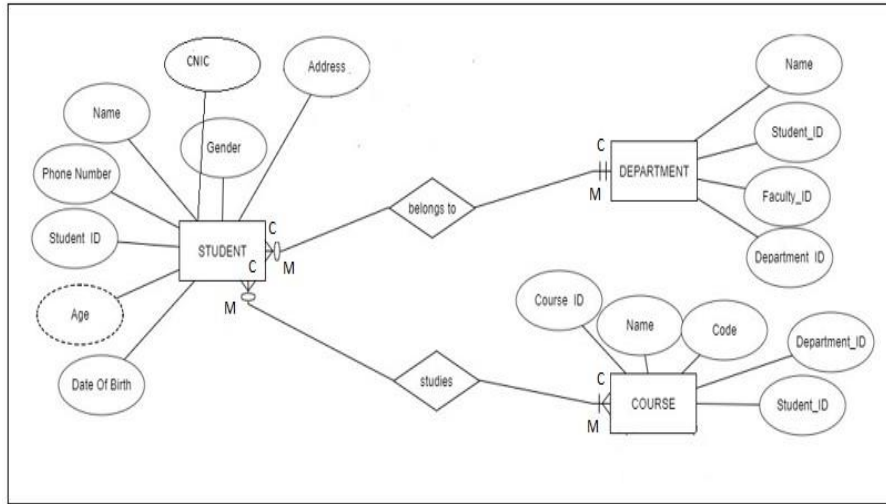

*Cardinality → C
Modality → M

* * * * *

NOTE: This is suggested (proposed) solution to the questions given in SECTION-B and C. Students can write any valid alternate answers.